

# Flex N Stretch™ Suspension Packs

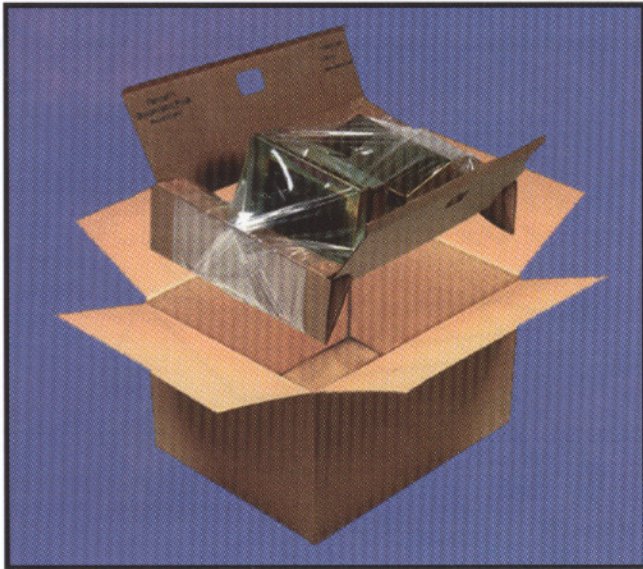

## Package Description:

Flex N Stretch Suspension Packs utilize transparent, elastomeric film to uniquely suspend or immobilize products within corrugated frames. The durable, tear-resistant film gently conforms to irregularly shaped products and, when under controlled tension, provides superior protection against shock and vibration. In addition, these packs arrive flat and completely assembled to minimize the required set up for usage of the packs. Simply *FLEX* the end panels up to load the product and *STRETCH* panels down to suspend product.

## Benefits:

- ❑ Unlike traditional packaging, ADE, Inc. Suspension Packs fold flat between uses to optimize storage space.
- ❑ Designed for easy set up to reduce packing labor requirements.
- ❑ Consolidate families of like-sized products in one pack size to reduce inventory requirements.
- ❑ Provides consistent product protection for multiple uses to reduce total packaging costs.
- ❑ Elastic memory of the suspension film provides protection for products with long shelf life or storage requirements.
- ❑ Compact designs to reduce cube of storing and shipping.
- ❑ Highlights packaged product to enhance perception.

## Custom Options:

Flex N Stretch Suspension Packs can be customized to meet your specific packaging requirements. Options include:

- Custom sizes and designs
- Custom printing of suspension insert or carton
- Corrugated board colors and weights
- Alternative film materials

## Package Designs:



Flex N Stretch UniPack  
Product Weight Range: 0-5#  
Applications: Handheld Computers, Hard Drives

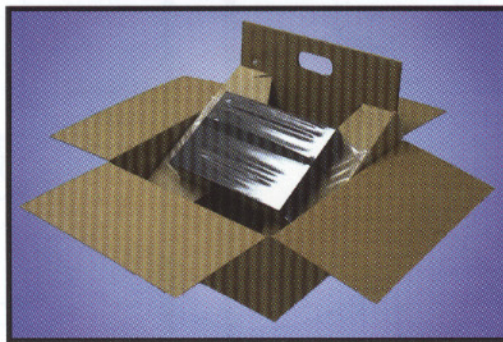

Flex N Stretch ULP  
Product Weight Range: 4-15#  
Applications: Laptop Computers, Medical Instruments

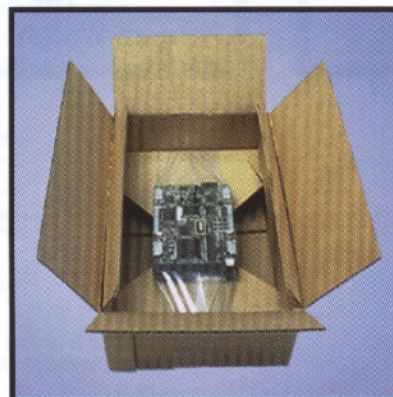

Flex N Stretch D-Pack  
Product Weight Range: 1-7#  
Applications: Computer Drives



Flex N Stretch M-Pack  
Product Weight Range: 10-70#  
Applications: Computer Monitors, CPUs

# Flex N Stretch Standard Designs

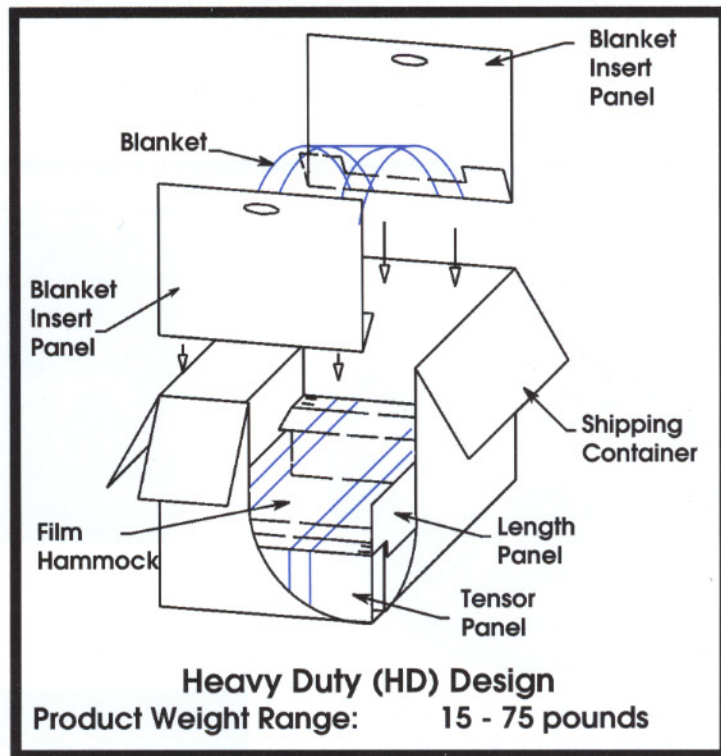
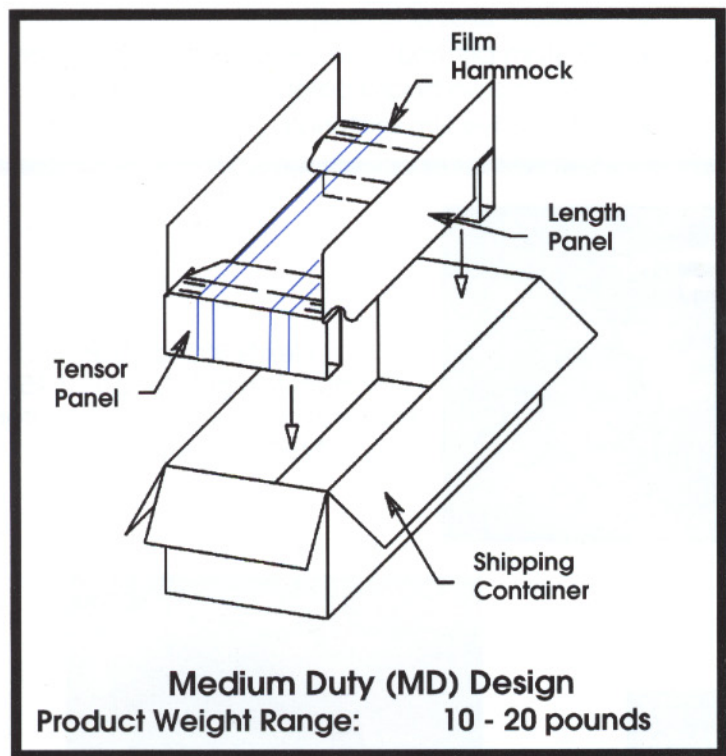
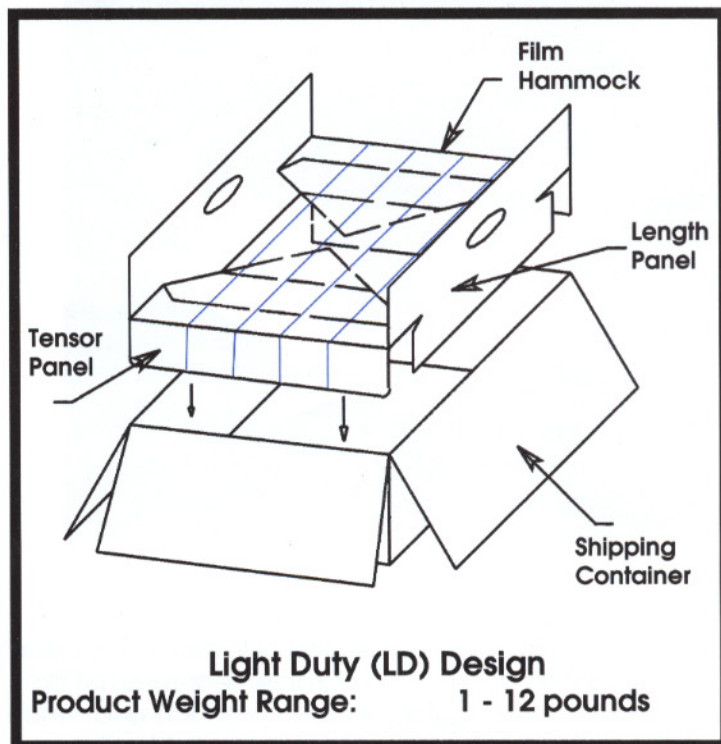
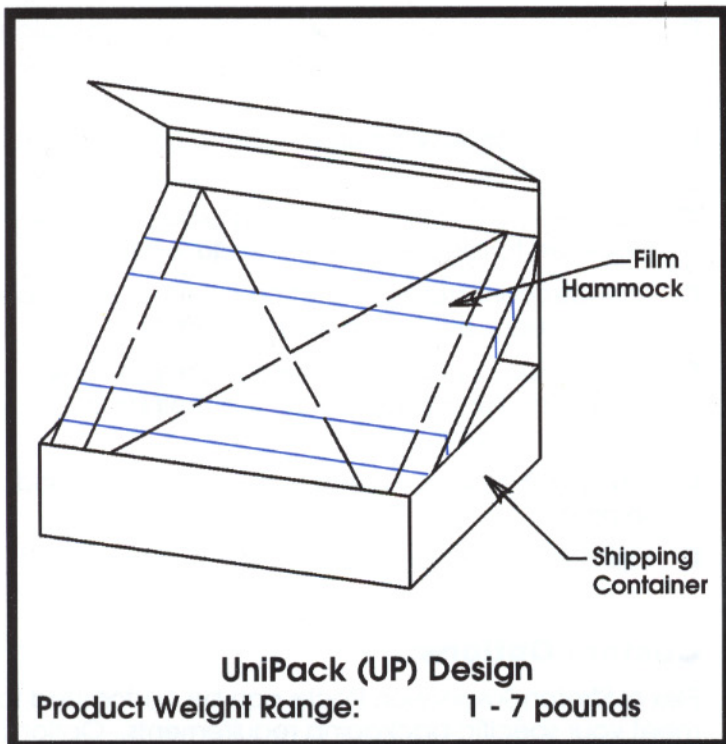

Flex N Stretch is a trademark of ADE, Incorporated  
© Copyright 2002, All Rights Reserved



ADE, Inc.  
1430 E. 130th Street  
Chicago, IL 60633

Phone: 1-800-222-0221  
Fax: 773-646-3400

**ADE, INC.**  
For What's Fragile in Your World

Website: [www.ade-usa.com](http://www.ade-usa.com)  
Email: [info@ade-usa.com](mailto:info@ade-usa.com)